

# 1941-48 FORD CARS



Don Hawley, San Diego, CA

TECHNICAL INFO FOR FIREWALLS.....	2
FIREWALLKITS .....	2
FRONT FLOORBOARDS .....	2
REAR FLOORBOARDS .....	3
TRUNK FLOORBOARDS.....	3
DEEP WHEEL WELLS.....	6
SMOOTHIE RUNNING BOARDS.....	5
AIR DEFLECTOR KIT .....	3
COWL VENT FILLER.....	3 & 7
CORE SUPPORT & FENDER APRON KITS .....	4
DASHBOARDS.....	5
ROCKER BOXES .....	5
UNIVERSAL PARTS.....	6

*All Prices are subject to change without notice.*

## 41 - 48 FORD FIREWALLS & TECHNICAL INFORMATION

### The Set-Back Information Provided on This Page Is For your Information

These references are to help you decide which firewall kit will best fit your particular application. There are many factors which will affect your choice of kits; engine set-back, radiator core thickness, air conditioning or super chargers. You need to determine the length of the engine package you intend to install & then figure out the distance you have from the back of the radiator core to the stock or existing firewall. To do this you will know how much extra room or set-back you will need. The firewall only fits in one place in the body, but your engine can be moved forward or backward as much as needed to obtain proper clearances. If you have any questions, please call our customer service dept. @ (928) 420-6346



**421000 41-48 FORD & MERC. FIREWALL Small Block**

Designed for passenger cars, this firewall has a 1 1/2" set-back with a 34" wide front opening.



**421002 41-48 FORD & MERC. FIREWALL Big Block**

Our big block firewall has a 4" set-back for you guys who like to use those really big motors.



**421105 41-48 FORD & MERC. FIREWALL EXTENSION - RH**  
**421106 41-48 FORD & MERC. FIREWALL EXTENSION - LH**

If you have a **convertible**, you must purchase these parts to go with the firewall to make your installation complete & neat.

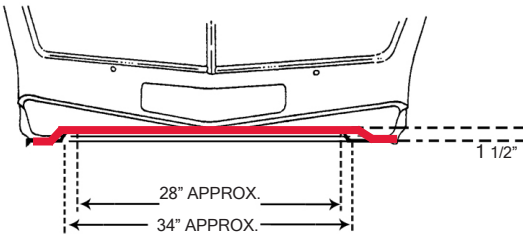

**421000 1941-48 FORD & MERCURY FIREWALL (1 1/2" SET-BACK) Small Block**

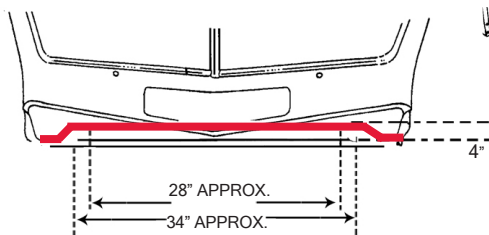

**421002 1941-48 FORD & MERCURY FIREWALL (4" SET-BACK) Big Block**

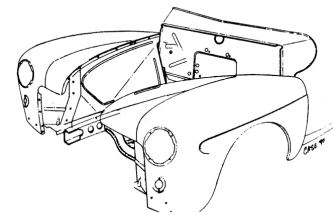

**NOTE:** These firewalls are designed for the most popular engine-transmission conversion which is Chevy engine & GMC turbo transmission. Any other engine installation (Ford, Mopar, etc.) may require rework of the bell housing area of the firewall.

## 41 - 48 FORD & MERCURY FRONT FLOORBOARDS



**421001 41-48 FORD & MERC. FRONT FLOOR - Small Block**

This kit matches up to our small block firewall #421000.



**421003 41-48 FORD & MERC. FRONT FLOOR - Big Block**

This kit will fit right up to our big block firewall #421002.



**421004 41-48 FORD & MERC. FRONT FLOOR - Universal**

This kit was designed to fit up to your stock firewall & still give you a redesigned floor that will clear the big automatic transmissions.

## 41 - 48 REAR & TRUNK FLOORBOARDS



\$330.

### 421034 41-48 FORD & MERC. REAR FLOOR

Match this floorboard up to our front floorboard kit & it makes your floor look very professional.

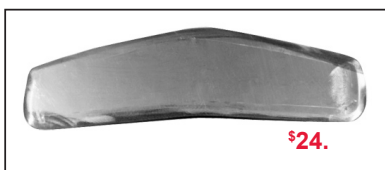

\$24.

### 421083 COWL VENT FILLER



\$315.

### 421090 41-48 FORD & MERC. REAR SEAT RISER REPAIR KIT

This is one of those kits that is not often not needed, but when you do need it, it's nice to have. With this kit, you get the seat riser under the front edge of the seat & the sheet metal under the seat along with complete set of how-to-instructions.

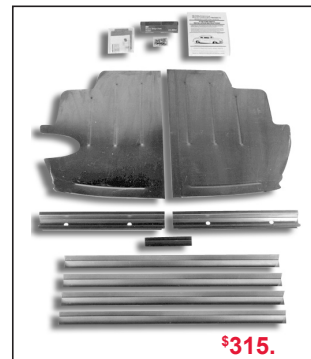

\$315.

### 421084 41-48 FORD & MERC. TRUNK REPAIR KIT

This kit allows you to replace the very bottom of your trunk floor. Each kit comes with enough angles & the sub-frame cross brace that almost always rusts out to make your installation easy.



\$358.

### 901010 DEEP WHEEL WELLS Universal

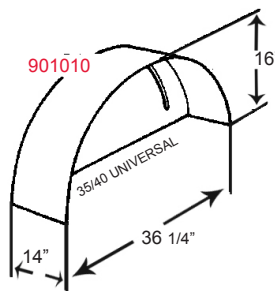

If you plan on putting wide wheels & tires on your car or pro-streeting it, we have just what you need. Our universal deep wheel well kit (B.P. No. 901010) was designed just for that purpose. These 18 gauge cold rolled all steel wheel tubs are 36" from end to end & a full 14" deep. You can install these beauties in as deep as you like for your particular project. All our deep wheel well kits have mounting angles.

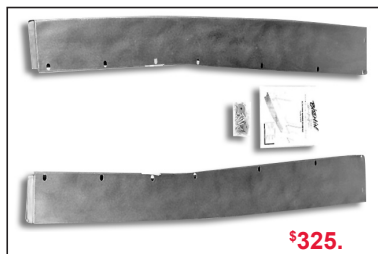

\$325.

### 421030 42-48 FORD & MERC. SMOOTHIE RUNNING BOARDS

Some of the original running boards either made of steel or aluminum are either bent or rusted out. We make a 16 gauge steel smoothie running board that we think is better than either of the originals. It's made a little wider to compensate for the removal of the molding. Either bolt them on as they come or weld them in & blend them into the body for a more modern, smoother look. NOTE: This part will fit a 1941 Ford with a small amount of modification & it will be flush like the 1942 to 1948 models.

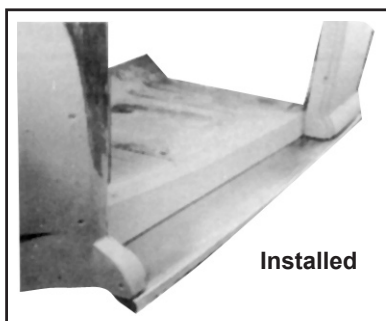

Installed



\$110.

### 421074 42-48 FORD AIR DEFLECTOR KIT

This 42-48 kit is a redesigned front pan. It replaces your stock pan with the useless crank hole in the middle. We think you will agree that this is a much cleaner looking pan than your old original pan. (Fits Ford only, will not fit Mercurys).

## 42 - 48 CORE SUPPORT & FENDER APRONS



\$360.

**421049 42-48 RADIATOR CORE SUPPORT**

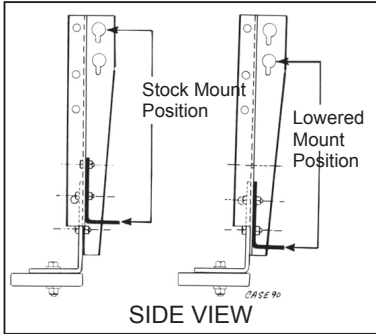

The 1942-48 Ford front sheet metal rides on a factory core support that is 'Y' shaped & has one mounting bolt in the middle. This allows the front sheet metal to rock & flex. As a result, the front sheet metal often out of alignment. We designed a posi-align core support that is a direct bolt-in. It mounts the sheet metal out on each frame rail that not only gives you plenty of adjustment where you had none before, but it assures you it will stay in place once aligned. The posi-align core support also allows you to mount your radiator 2 1/3" lower than stock, which in turn lets you use a flex fan instead of an electric fan. The core support kit comes with a front lower air deflector kit. The air deflector really cleans up the area behind the grill. (Fits Ford only, will not fit Mercurys.)



\$380.

**421042 FORD SMOOTHIE KIT INNER APRONS**



\$460.

**421046 FORD LOUVERED KIT INNER APRONS**

The 42-48 Ford has some strange shaped front inner fender aprons. We redesigned them to allow more air in & for a better look. Made of 18 gauge steel with a bead rolled into them, they are really a work of art. Our louvered aprons have 64 louvers. When we redesigned them the stock stone shields no longer fit, so we made new ones. They now fit, are larger & look better. We included them in each kit. They bolt up to your stock core support or our posi-align core support.

*Try'em you'll like'em.*

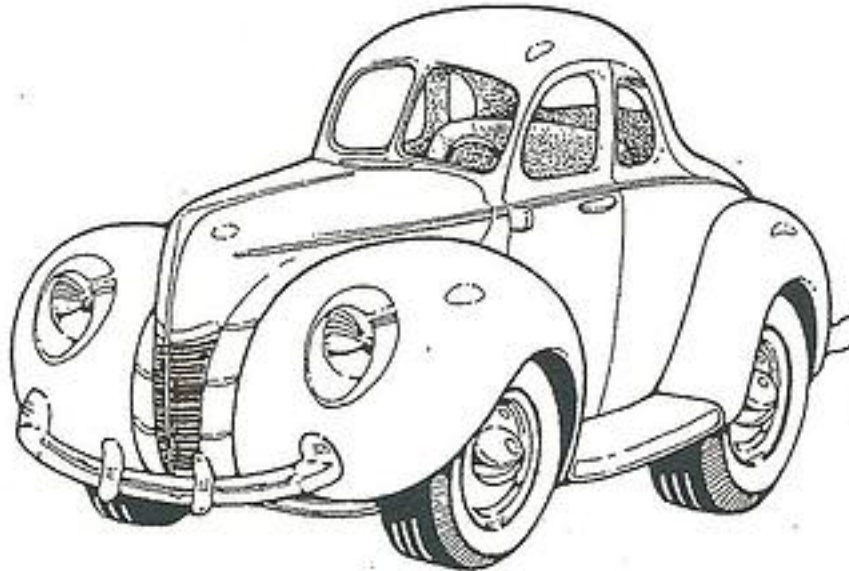

## 41 - 48 FORD DESIGNER DASHBOARDS

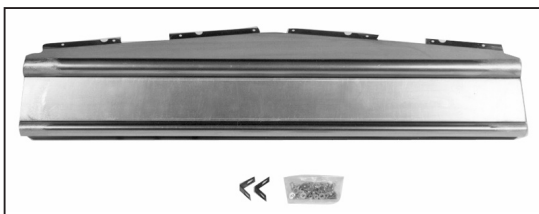

Out of the Box



Sample of Wood Finish

YEAR OF VEHICLE	PART #	PRICE
41-48 FORD & MERCURY - Steel Face	421078	\$350.
NOTICE: Face is 4 3/4" wide - Custom widths - \$35.00		

HIDE-A-SWITCH panels for your new dash. This bolt-on accessory comes in one piece & can be sectioned & fit to steering column drops or consoles. It can be turned at two different angles to give you a 2" or 3" face. We offer two different lengths - 47" & 60" for wider cars.

- 371038** Hide-A-Switch - 47" - \$65.
- 371041** Hide-A-Switch - 60" - \$70.

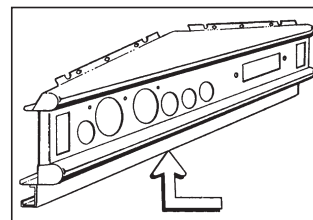

## 41 - 48 FORD ROCKER BOXES



**421022** CENTER ROCKER BOX  
Passenger Side

\$240.

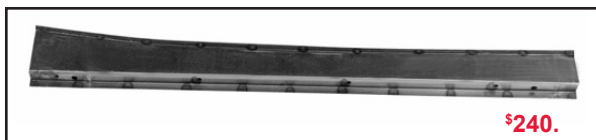

**421023** CENTER ROCKER BOX  
Drivers Side

\$240.

One of the really bad trouble spots on any 1941-48 Ford or Mercury has always been the rocker boxes. This box-like body stiffener runs from the firewall area to the rear wheel house on both sides on the car.

They have a tendency to rust out because the originals are very thin on the inside & they fill with dirt. Bitchin Parts.® does not make just an outer skin, we make a complete rocker box with the nut plates welded into place for the running boards. Since these are very long in the completed stage we decided to offer them in sections. Each side is available in three sections.

You can purchase all or just one part if that is all you need. These boxes are manufactured of 16 gauge cold rolled steel.

If you have any questions give us a call at **(928) 420-6346** & we will be glad to help.

### Long Door Cars

The 1941-48 Ford & Mercury 2 Door Sedans, Sedan Coupes (w/backseats) & the Convertibles are considered "long door cars". This means the length of the front door from the front to the rear is 44" long when measured at the belt line.

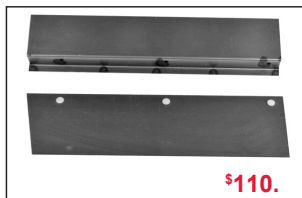

**421060** REAR ROCKER BOX  
Passenger Side

\$110.

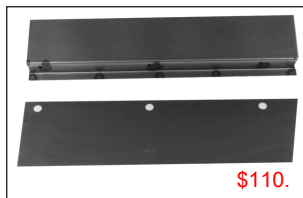

**421061** REAR ROCKER BOX  
Driver Side

\$110.

### Short Door Cars

The 1941-48 Ford & Mercury 4 Door Sedans, Business Coupes (no backseats) & Sedan Deliveries are considered "short door cars". This means the length of the front door from the front to the rear is 35 1/2" long when measured at the belt line.



**421098** CNTR. ROCKER BOX  
Passenger Side

\$230.



**421099** CNTR. ROCKER BOX  
Drivers Side

\$230.



**421102** REAR ROCKER BOX  
Passenger Side

\$115.

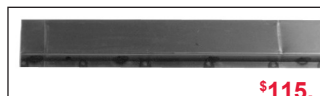

**421103** REAR ROCKER BOX  
Drivers Side

\$115.



**421066** FRNT. ROCKER BOX  
Passenger Side

\$155.



**421067** FRNT. ROCKER BOX  
Drivers Side

\$155.

**Front Rocker  
Boxes  
Fit  
All Models**

**Call  
1-928-420-1254  
To Order Today**  
or visit our web site

[www.absolutesheetmetal.com](http://www.absolutesheetmetal.com)

## UNIVERSAL FLOORS

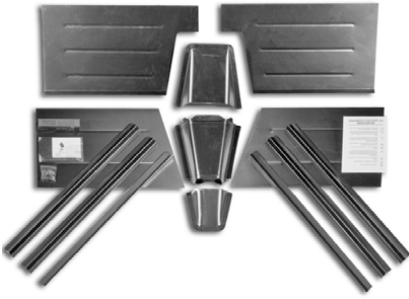

**901030 \$325** All Purpose Front Floor Kit



**901035 \$325** All Purpose Rear Floor Kit

## BATTERY BOXES

### BATTERY BOXES

Group 42	901020	\$110.00
Group 71	901006	\$110.00
Optima Box	901040	\$110.00

Mounting a battery in a street rod has always created problems, some major and some minor. Our battery box kits will solve most of the problems. The universal mounting brackets supplied with these kits allow you to choose the mounting method which best suits your application, including flush floor mounting, side mounting, or halfway through the floor for extra ground clearance. We offer three kits. The positive battery hold down, adequate ventilation & cable protection give added security to your battery installation.

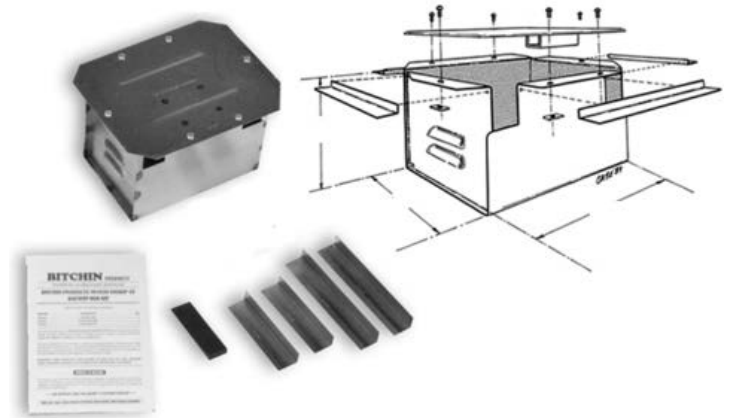

Group 42: 9 3/4 L x 7 W x 7 1/2 H  
 Group 71: 8 1/2 L x 7 1/4 W x 9 1/4 H  
 Optima: 10 1/2 L x 7 1/4 W x 8 1/2 H

## UNIVERSAL DEEP WHEEL TUB



**901010 \$358** Deep Wheel Tubs Universal

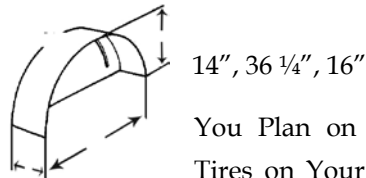

You Plan on Putting Wide Wheels & Tires on Your Car or Pro-Streeting it, We Have Just What You Need. Our Universal Deep Wheel Tub Kit (No. 901010) Was Designed for Just That. These 18 Gauge Cold Rolled All Steel Wheel Tubs Are 36" From End to End & a Full 14" Deep. You Can Install These Beauties In As Deep As You Like for Your Particular Project. All Our Deep Wheel Tub Kits Have Mounting Angles.

## COWL VENT FILLERS

### CARS

CAR YEAR / TYPE	PART #	PRICE
32' Ford Car	321097	\$24.
33'-34' Ford Car	331084	\$24.
35'-36' Ford Car	351082	\$24.
37'-40' Ford Car	371037	\$24.
41'-48' Ford & Mercury Car	421083	\$24.
37'-39' Chevy Car	737200	\$24.
40' Chevy Car	740111	\$24.

### TRUCKS

TRUCK YEAR / TYPE	PART #	PRICE
32'-34' Ford Truck	321097	\$24.
35'-36' Ford Truck	331084	\$24.
37'-47' Ford Truck	371037	\$24.
48'-52' Ford Truck	481037	\$24.
47'-53' Chevy Truck (Top)	751023	\$24.
47'-50' Chevy Truck (Side)	751024	\$24.
54'-55' Chevy Truck (Top)	751060	\$24.

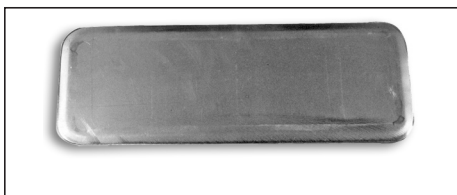

**321097** 32' Ford Car

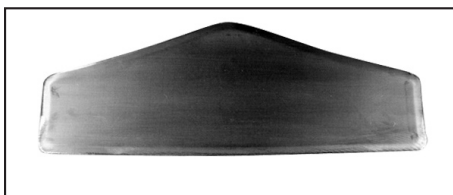

**331084** 33'-34' Ford Car & 35'-36' Ford Truck

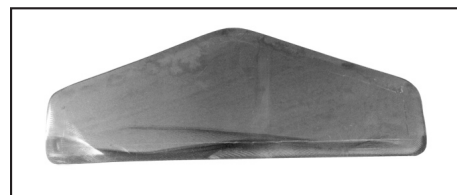

**351082** 35'-36' Ford Car



**371037** 37'-40' Ford Car & 37'-47' Ford Truck

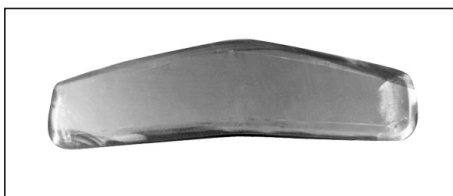

**421083** 41'-48' Ford & Mercury Car



**481037** 48'-52' Ford Truck

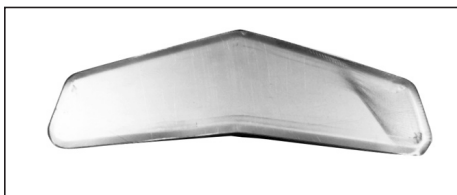

**737200** 37'-39' Chevy Car

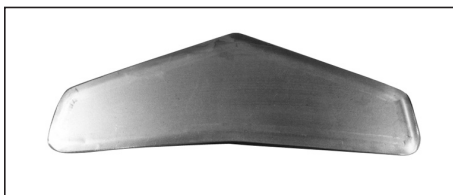

**740111** 40' Chevy Car

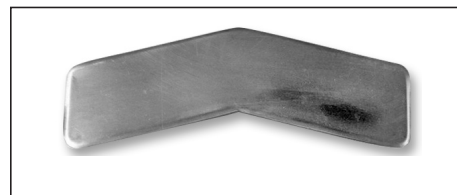

**751023** 47'-53' Chevy Truck (Top)



**751024** 47'-50' Chevy Truck (Side)

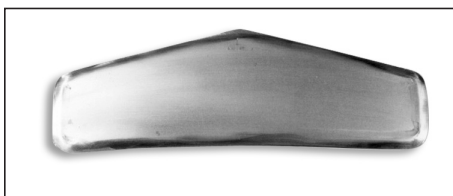

**751060** 54'-55' Chevy Truck (Top)



Our Cowl Vent Fillers are made from 18 Gage cold rolled steel & are a little larger than the Stock Cowl so they can be trimmed for a perfect fit. The edges are beveled so the weld area is below surface making it easier for a flush fit. Swap meet the original, & pocket the difference.

# **Bitchin' T-Shirts Now Available!**



Jeff Hill, Owner, modeling our t-shirt while working in his shop.

**ONLY \$15.95!**

**Sizes: Medium to 3XL  
Black or White T-Shirt**